

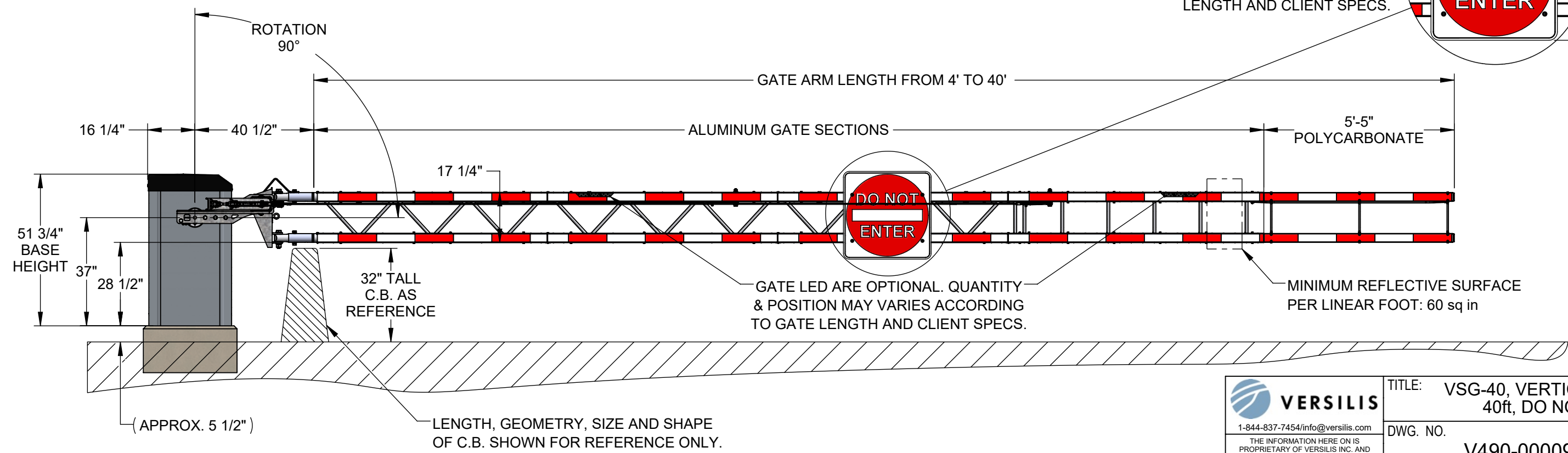

PANEL SHOWN AS REFERENCE. QUANTITY, TYPE, SIZE & POSITION MAY VARIES ACCORDING TO GATE LENGTH AND CLIENT SPECS.

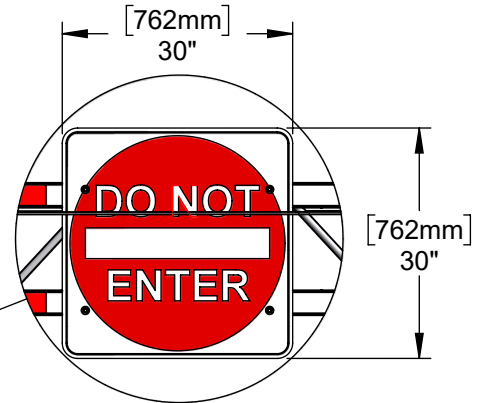

C.B. : CONCRETE BARRIER

LENGTH, GEOMETRY, SIZE AND SHAPE OF C.B. SHOWN FOR REFERENCE ONLY.

 <b>VERSILIS</b> 1-844-837-7454/info@versilis.com <small>THE INFORMATION HERE ON IS PROPRIETARY OF VERSILIS INC. AND SHALL NOT BE DISCLOSED, DUPLICATED OR USED OTHERWISE WITHOUT THE EXPRESS WRITTEN APPROVAL OF VERSILIS INC.</small>	TITLE: VSG-40, VERTICAL SWITGATE 40ft, DO NOT ENTER	
	DWG. NO. V490-000097-000	REV. B
DATE 2024-08-07	SCALE 1:36	SHEET 1 OF 1